

inspec.x Lenses

High-Performance Lenses
for Large Sensors



inspec.x L 5.6/105

High-Resolution Lenses for Line-Scan Applications

The inspec.x L Series was developed to meet the highest requirements in industrial image processing with very large sensors. This Lens Series shows even contrast and resolution over an image circle of up to 82 mm. The field-proven performance makes these lenses a perfect match for sensors like the popular 12k/5 μ m and 16k/5 μ m line-scan sensors. Very large area-scan sensors also benefit from the high resolution, low distortion and excellent color correction of these lenses.



The four variants of the inspec.x L 5.6/105 are optimized for magnifications of 0.33x, 0.5x, 0.76x and 1x respectively. The V-groove interface at both ends of the lens enables adjustment to the best azimuth position and use of the lens in retro position for magnifications up to 3x. All lenses feature lockable iris and are engineered for the use in harsh industrial environments.

- Large image circle up to 82 mm
- Perfect match with 5 μ m pixel size
- Full-metal barrel
- Lockable aperture

- Focal length: 105 mm
- Aperture: 5.6 ... 11
- Working distance: 100-420 mm
- Spectral range: 400-750 nm
- Distortion: < 0.4%
- Camera mount: V-groove
- Compatible with all inspec.x L Series accessories

Not exactly what you need? Qioptiq is your partner for custom developments: from alterations of standard products to complete custom modules.

inspec.x L

Product	Focal length (mm)	F-number	Magnification range	Image circle (mm)	Interface	Part No.
inspec.x L 5.6/105 1.0x	105	5.6	-0.85 ... -1.2	82	V-groove	0703-082-000-20
inspec.x L 5.6/105 0.76x	105	5.6	-0.6 ... -0.9	82	V-groove	0703-083-000-20
inspec.x L 5.6/105 0.5x	105	5.6	-0.4 ... -0.65	82	V-groove	0703-084-000-20
inspec.x L 5.6/105 0.33x	105	5.6	-0.25 ... -0.45	82	V-groove	0703-085-000-20

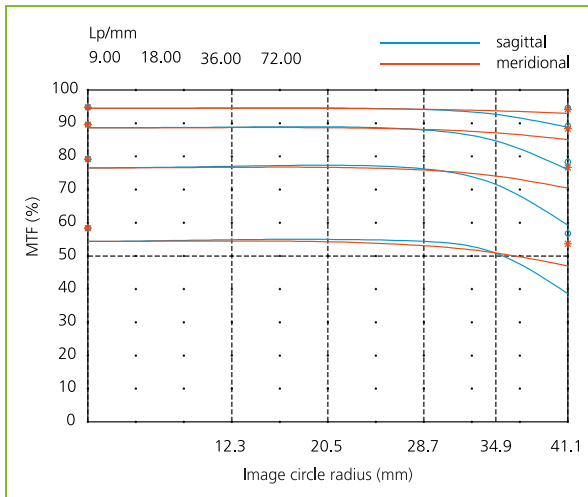

Some example applications are:

- PCB inspection
- Display inspection
- Film and slide digitization
- High-end book scanning
- Glass inspection
- High-resolution web inspection
- 3D imaging

MTF of inspect.x L 5.6/105 -0.5x @ $\beta' = -0.5$ and f-stop = 5.6

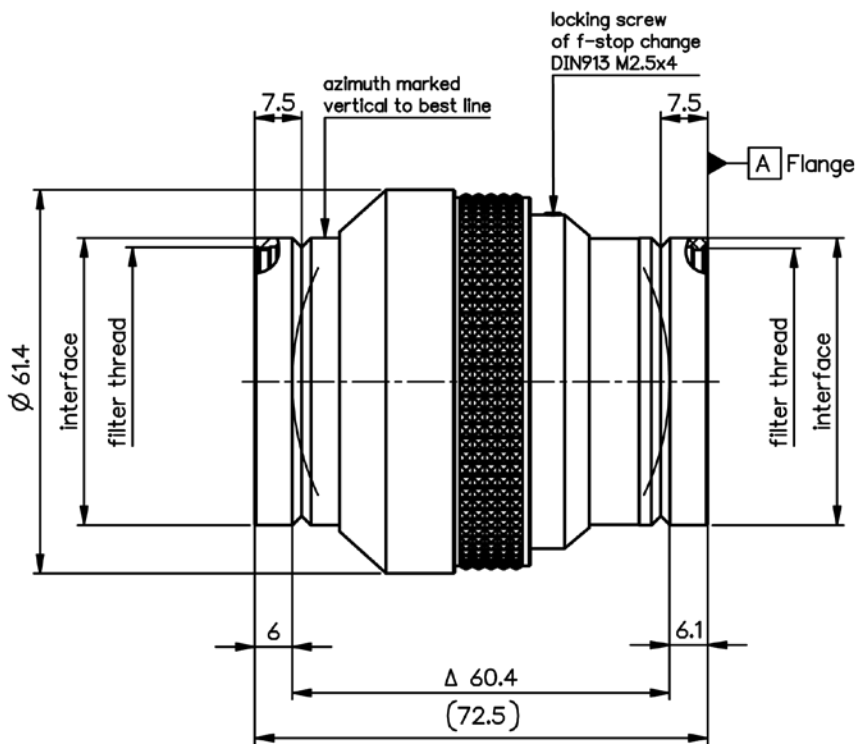

inspect.x L 5.6/105 -0.5x

inspec.x L 5.6/105 float

High-Resolution Lens with Wide Magnification Range

The inspec.x L 5.6/105 float lens combines the field-proven imaging performance of the inspec.x L 5.6/105 series with newly developed mechanics to cover a large magnification range with only one lens.

By using floating element optics the inspec.x L 5.6/105 float achieves high performance over an extremely wide magnification range from 0.3x to 3.0x. A full-metal housing makes the lens suitable for industrial use and geared rings facilitate the use in automated environments.



- Ideal for 12 k and 16 k sensors
- Geared rings for magnification and aperture
- Large image circle up to 82 mm
- Focal length: 105 mm
- Aperture: 5.6 ... 11
- Extreme magnification range of 0.3x ... 3x
- Floating element optics
- Perfect match with 5 μm pixel size
- Image circle: 82 mm
- Working distance: 100-420 mm
- Spectral range: 400-750 nm
- Distortion: < 0.4%

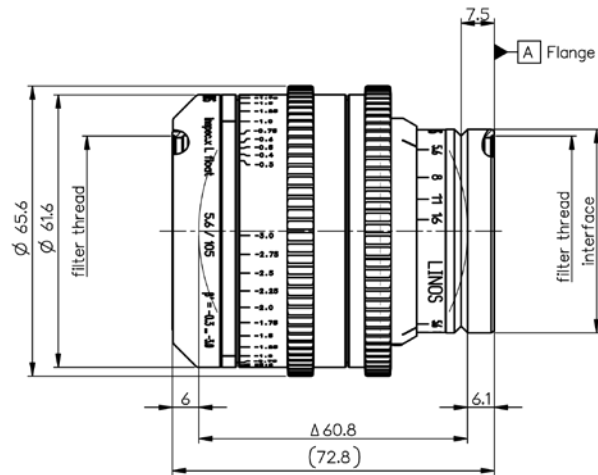

inspec.x L 5.6/105 float

Product	Focal length (mm)	F-number	Magnification range	Image circle (mm)	Interface	Part No.
inspec.x L 5.6/105 float	105	5.6	-0.3 ... -3.0	82	V-groove	0703-114-000-20

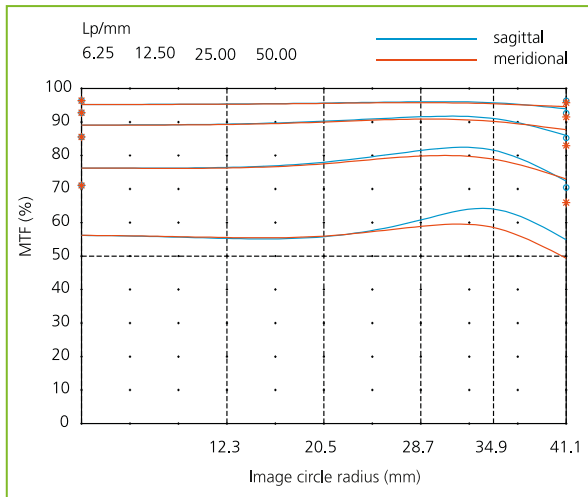

MTF of inspect.x L 5.6/105 float @ $\beta' = -0.5$ and f-stop = 5.6

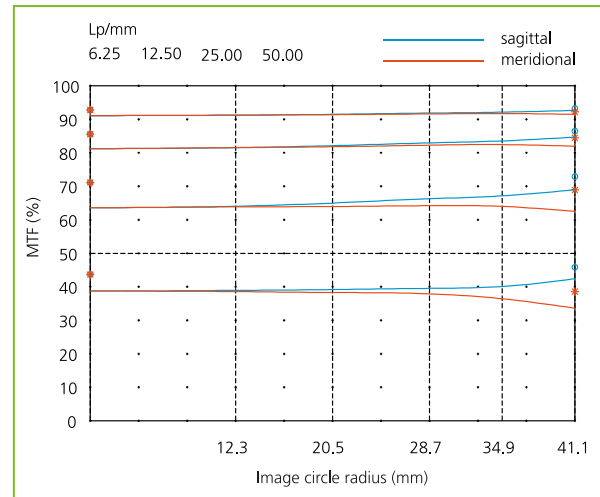

MTF of inspect.x L 5.6/105 float @ $\beta' = -2.0$ and f-stop = 5.6

Parameters - DIN 58 405	
Number of teeth N	80
Module m	0.8
pitch circle d	64.0
angle of pressure	20°
reference profile	DIN 867

Parameters of the gear wheels

β'	angle	working distance	Flange - Image
-0.3	22.60°	417.5	96.1
-0.5	16.14°	276.5	117.6
-0.75	8.08°	205.9	144.2
-1.0	0.00°	170.6	170.7
-2.0	32.28°	117.4	276.1
-3.0	64.56°	99.6	381.1

Working and flange focal distances for different magnifications

inspec.x L 4/105

High-Resolution Lenses for High Magnification Imaging

This inspec.x L 4/105 Series lens was developed to achieve an object resolution down to 2 μm . These lenses are designed for sensors with up to 82 mm length and achieve an enormous resolution of up to 200 lp/mm in the object plane. This high imaging quality is achieved across the complete image circle. Another advantage is the extremely small distortion, which is well under 1 μm over the complete field of view.

The inspec.x L 4.0/105 Series is the perfect match for modern, high-resolution 12k/5 μm and 16k/5 μm cameras for applications that require extremely high resolution. Three different magnifications of 3x, 3.5x and 5x are available. All three magnifications can also be ordered in a version that is optimized for a prism beamsplitter on the object side for coaxial illumination (see opposite page for details).

- Outstanding MTF performance over the entire image circle
- Diffraction-limited optical design
- High numerical aperture
- Focal length: 105 mm
- Magnifications: 3x, 3.5x, 5x
- Image circle up to 82 mm
- Spectral range: 400-750 nm
- Iris diaphragm: manual, lockable
- Mount: V-groove
- Wide range of mechanical accessories

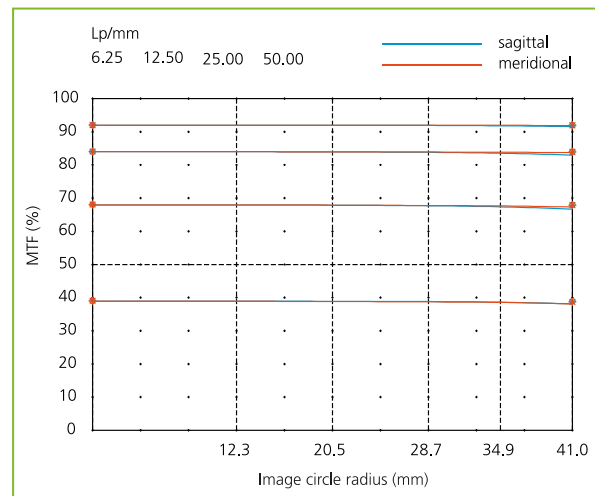

MTF of inspec.x L 4.0/105 -3.5x @ $\beta' = -3.5$ and f-stop = 4

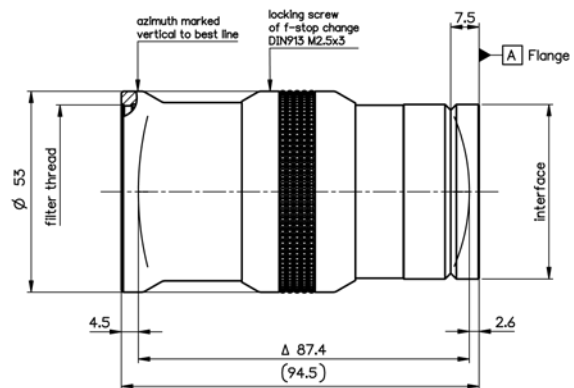

inspec.x L 4.0/105 -3.5x

inspec.x L 4/105

Product	Focal length (mm)	F-number	Magnification range	Image circle (mm)	Interface	Part No.
inspec.x L 4.0/105 -3.5x	105	4.0	-3.3 ... -3.7	82	V-groove	0703-095-000-21
inspec.x L 3.5/105 -5.0x	105	3.5	-4.8 ... -5.2	82	V-groove	0703-102-000-20
inspec.x L 4.0/105 -3.0x	105	4.0	-2.8 ... -3.3	82	V-groove	0703-104-000-20
inspec.x L 4.0/105 -3.0x prism	105	4.0	-2.8 ... -3.3	82	V-groove	0703-105-000-20
inspec.x L 4.0/105 -3.5x prism	105	4.0	-3.3 ... -4.0	82	V-groove	0703-107-000-20
inspec.x L 3.5/105 -5.0x prism	105	3.5	-4.8 ... -5.2	82	V-groove	0703-108-000-20

inspec.x L Prism Module

Beam Splitter Prism for High-Resolution Lenses

Coaxial illumination is very common for high-resolution applications. Qioptiq offers an easy-to-use prism module that is optimized for the use with the prism type inspec.x L lenses. This prism module has a universal mount for fiber guides that are widely used for line-scan illumination. The setup of this system is very straight forward and results in a complete optical system of lens and illumination unit that achieves diffraction limited performance.

The prism module is designed for the lenses:

- inspec.x L 4/105 -3x prism
- inspec.x L 4/105 -3.5x prism
- inspec.x L 3.5/105 -5x prism



inspec.x L prism lens with prism module



Beam splitter prism

Product	Part No.
Prism module	0703-107-824-00

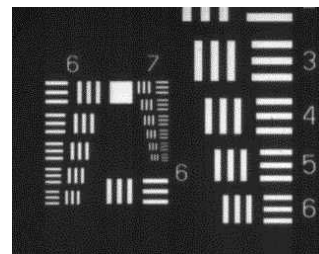

USAF-Testchart exposure with a Dalsa Piranha HS 12k in area-mode and 430 nm illumination. Element 6 of group 7 could be resolved, which means up to 228 lp/mm at a field of view of 17.8 mm.

inspec.x L 4/60 and 4/100

High-Resolution Lenses for Small Magnifications

The inspec.x L 4/60 and 4/100 are optimized for the use from infinity down through magnifications of around 0.2x. In this range these lenses show exceptional contrast over a large sensor size of up to 70mm. High contrast goes along with very good color correction and low distortion. Especially the 60mm lens provides unusually high performance for such a short focal length and enables imaging of large objects in space constrained environments with large sensors.

Both lenses feature a threaded interface to use them with the popular Modular Focus helical mount that provides access to virtually all existing cameras via different camera adapters.



- High contrast for small magnifications
- Excellent color correction
- Focal length: 60 and 100 mm
- Magnifications: infinity ... 0.2
- Image circle up to 70 mm
- Spectral range: 400-750 nm
- Iris diaphragm: manual, click-stop or continuous with set screw
- Mount: compatible to Modular Focus

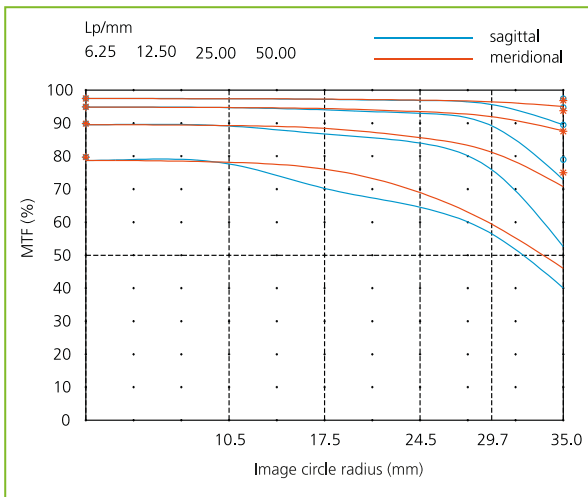

MTF of inspec.x L 4/100 @ $\beta' = -0.05$ and f-stop = 5.6

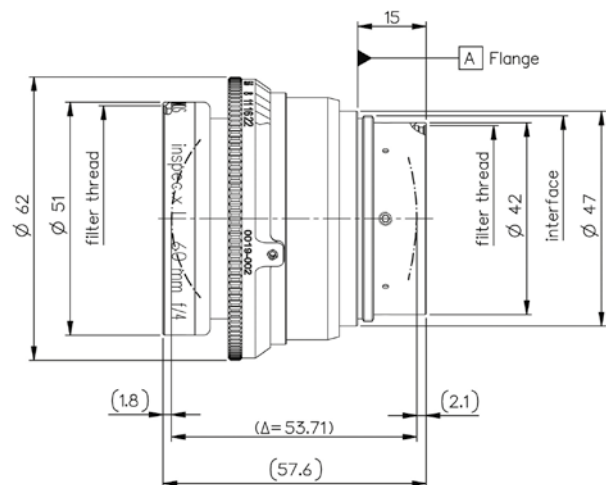

inspec.x L 4/60

inspec.x L 4/60 and 4/100

Product	Focal length (mm)	F-number	Magnification range	Image circle (mm)	Interface	Part No.
inspec.x L 4.0/60	60	4.0	0 ... -0.2	70.8	M45x0.75	0019-002-000-50
inspec.x L 4.0/100	100	4.0	0 ... -0.2	70.4	M45x0.75	0019-003-000-50

inspec.x M

Lenses with Large Aperture for Low-Light Line-Scan and Area-Scan Applications

The inspec.x M Series closes the gap between the outstanding C-Mount MeVis-C lenses and the large format inspec.x L lenses.

Equipped with lockable manual focus and manual iris these F-Mount lenses are the ideal choice for sensors up to 35 mm format when a fast f/# is required. The 1.4/50 mm lens is available for visible spectral range or near-infrared. The NIR version lens features a coating for the range from 900 to 1350 nm, making it an ideal choice for applications like electro- and photoluminescence

- Large magnification range
- Very high numerical aperture
- Low distortion
- Optical magnification: -0.07
- Image circle: 43.3 mm
- Max. sensor size: 35 mm format
- Camera mount: F-Mount
- Focusing: manual, lockable
- Iris diaphragm: manual, lockable

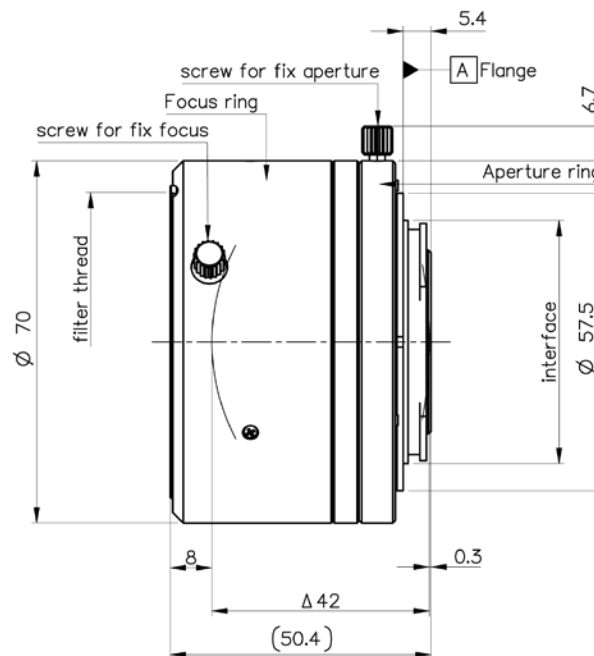

inspec.x M

Product	Focal length (mm)	F-number	Magnification range	Image circle (mm)	Interface	Part No.
inspec.x M 1.4/50	50	1.4	0 ... -0.15	43.3	F-Mount	0009-243-000-40
inspec.x M NIR 1.4/50	50	1.4	0 ... -0.15	43.3	F-Mount	0009-243-000-42

MachVis Software

Lens Selection Software

MachVis software is designed to help you find the right lens for your machine vision application. Starting with four simple parameters:

- Object size
- Working distance
- Sensor size
- Camera mount

MachVis calculates the necessary optical parameters and then, from the extensive LINOS Lens catalogue, selects all suitable lenses that meet your specifications.

If mechanical accessories (e.g. focussing units, extension tubes etc.) are needed, MachVis will create a printable, itemized list of the required parts. MachVis also generates a schematic drawing of the lens and accessories in the order of assembly.

Specifications, along with your own project notes, may be saved to disk for later recall. Data-sheets (PDF) for each lens may be viewed for a more detailed analysis.

For download and further information, please go to www.qioptiq.com/machvis.

Workflow: From the choice of lens...



to the three-dimensional model...



to the final system

Mechanical Accessories

Mechanical Adapters

LINOS Machine Vision Lenses have different threads and most have no focusing device. Therefore, we offer a complete range of mechanical accessories to adapt the lenses to all types of camera systems.

Modular Focus

A helical mount with locking screw and travel range of 25 mm. Lenses are mounted via an M45 thread using the various lens adapters and extension tubes that Qioptiq offers. A large variety of camera adapters is mounted directly with three set screws. The complete setup can be rotated freely for best azimuth or convenient access to aperture and

locking screw. Smart mechanical design of the Modular Focus prevents the lens from rotating during focusing.

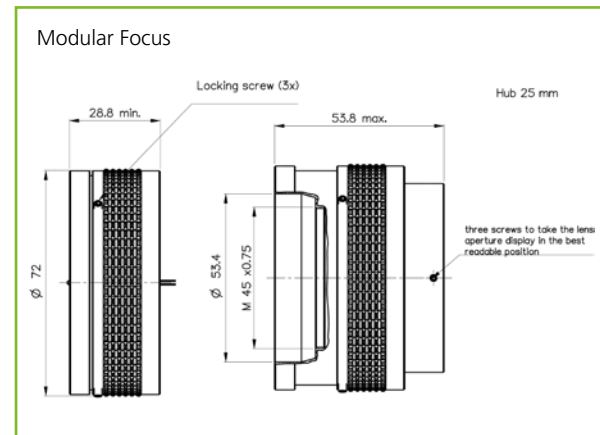

11

Modular Focus

Product	Part No.
Modular Focus Helical mount	2408-009-000-42
Extension tube 24.5 mm M45x0.75	2408-009-113-00
Extension tube 60 mm M45x0.75	2408-009-123-00
Extension tube 87.5 mm M45x0.75	2408-009-122-00



Modular focus

Focus Tube inspec.x L 105

Product	Part No.
Focus tube M72 for inspec.x L 105 mm -0.33x and -0.5x	2408-012-000-31
Focus tube M72 for inspec.x L 105 mm -0.76x and -1.0x	2408-012-000-30
Focus tube M72 for inspec.x L 105 mm -3.0x and -3.5x	2408-012-000-47
Focus tube M72 for inspec.x L 105 mm -5.0x	2408-012-000-33
Focus tube M95 for inspec.x L 105 mm -0.33x and -0.5x	2408-012-000-41
Focus tube M95 for inspec.x L 105 mm -0.76x and -1.0x	2408-012-000-43
Focus tube M95 for inspec.x L 105 mm -3.0x and -3.5x	2408-012-000-46
Focus tube M95 for inspec.x L 105 mm -5.0x	2408-012-000-45



Focus Tube inspec.x L 105

Camera Adapter

Product	Part No.
Camera adapter C-Mount	2408-009-106-00
Camera adapter F-Mount	2408-009-142-00
Camera adapter M42x1	2408-009-119-00
Camera adapter M48x0.75	2408-009-148-00
Camera adapter M58x0.75	2408-009-132-00
Camera adapter M72x0.75	2408-009-134-00
Camera adapter M90x1.0	2408-009-166-00
Camera adapter M95x1.0	2408-009-155-00

Camera Extension Tubes

Product	Part No.
Extension tube M72x0.75-24mm	2408-009-135-00
Extension tube M90x1.0-24mm	2408-009-167-00
Extension tube M95x1.0-24mm	2408-009-156-00

Lens Adapter

Product	Part No.
Lens adapter M45 V-groove	2408-009-147-00



Discover the Q!

Discover the capabilities, knowledge, equipment and technology of Qioptiq

The Vision Technology portfolio area covers the whole range of industrial imaging tasks from Macro to Micro and Line-Scan to Area-Scan.

Photonics for Innovation

Contact Qioptiq today:

Email: inspection@excelitas.com

www.qioptiq.com

www.qioptiq-shop.com

www.excelitas.com

Europe

Phone: +49 (0)551 69 35-0

North America

Phone, toll free: +1 (800) 429-0257

Asia / Pacific

Phone: +65 6499 7777